

Refinery Petrochemical Integration Alternate Routes to Produce Paraxylene

Jacques Rault

- Ø **Slowly recovering**
- Ø **Economy of scale**
- Ø **Production cost reduction**
 - **Technology**
 - **Reduce Investments**
 - **Lower feedstock costs**

Typical ParamaX Configuration

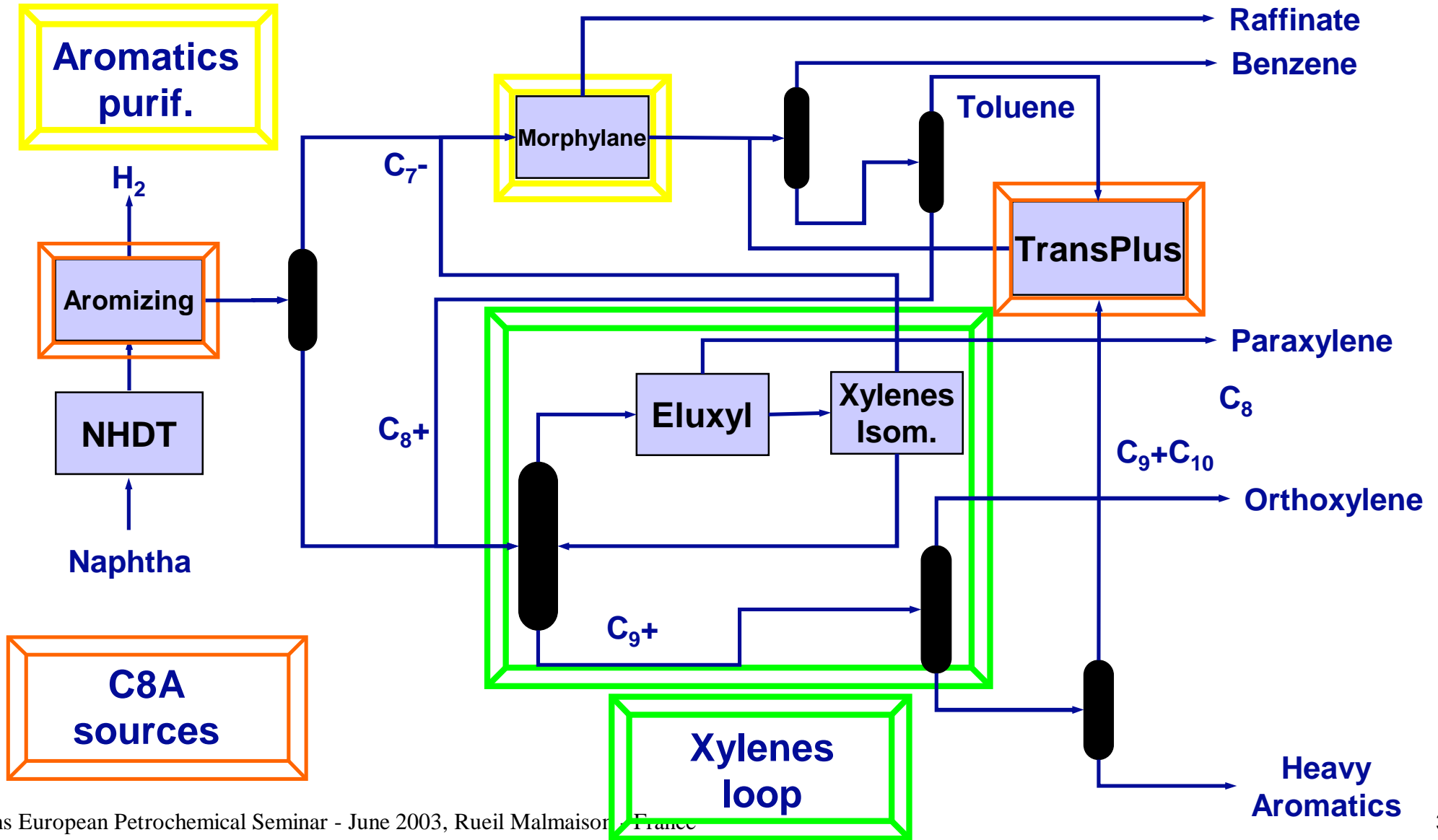

ParamaX Blocks Function

Ring generation

Aromatics purification

Ring rearrangement

PX separation

Ring rearrangement

Aromizing

Morphylane

TransPlus

Eluxyl

Oparis / Xymax

Base Case - Aromatics Survey

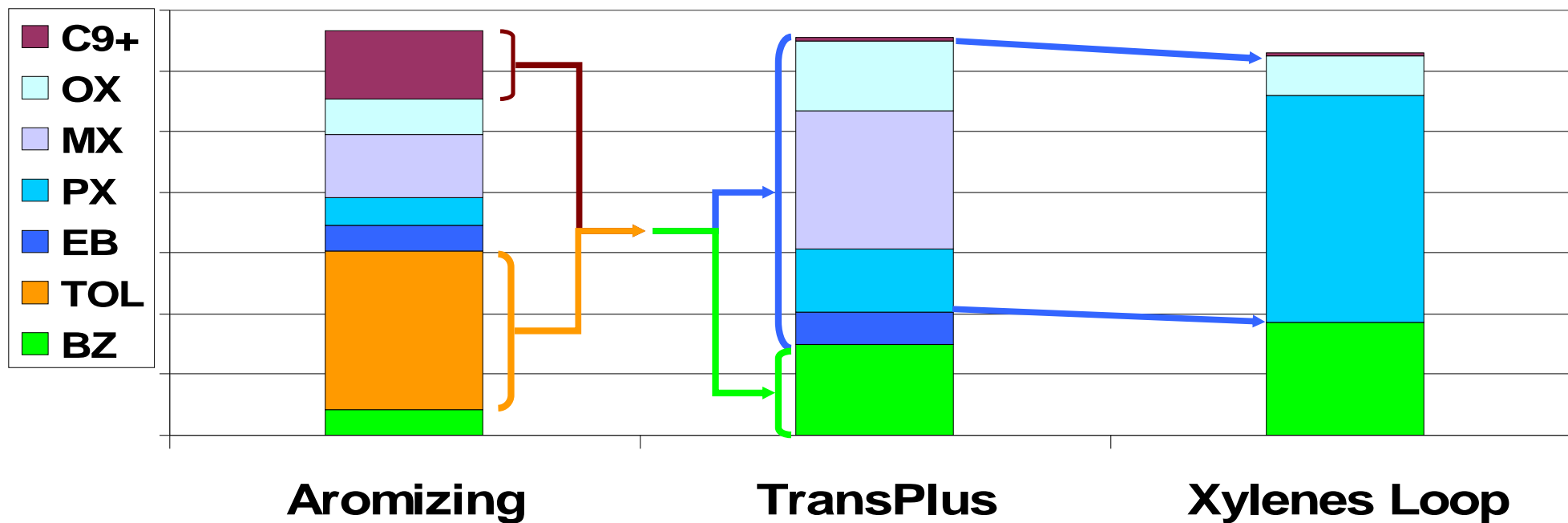

**TransPlus yields 50% of C8A
to the Xylenes Loop**

Methyl group rearrangement, long radicals dealkylation

C8A, wt % on conv.

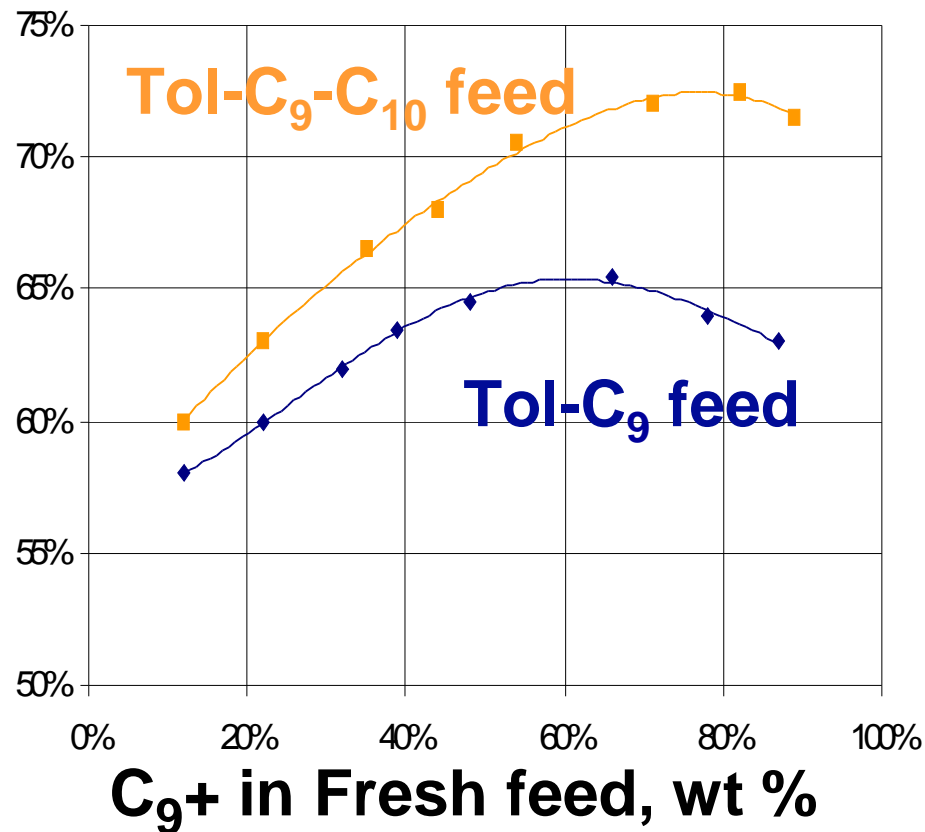

- **Jointly developed between ExxonMobil and CPC (Taiwan)**
- **Processes C10-C11 Aros: superior yields**
- **High WHSV, low H₂/HC**
- **First reference started in June 1997, 6 years first cycle**

Base Case Capex And Opex Contributions

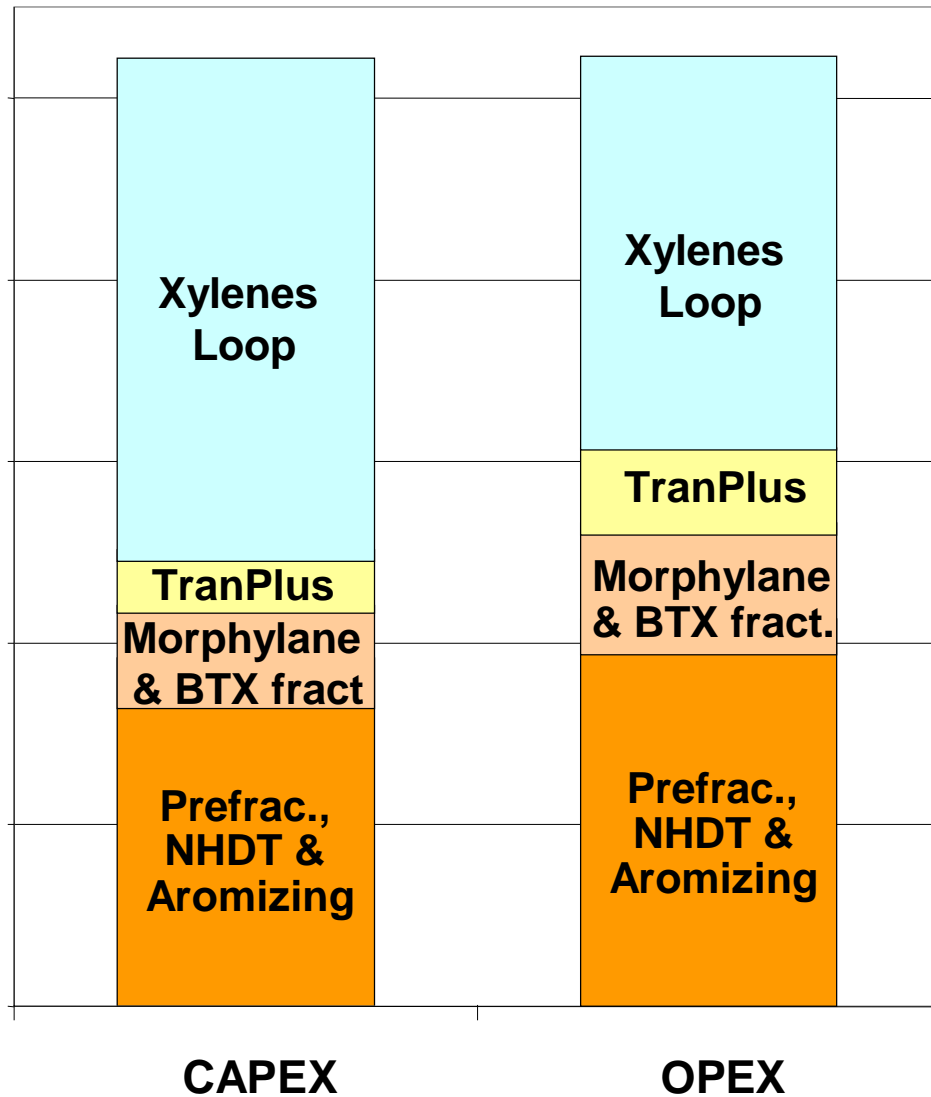

Aromatics ring generation has an important contribution

- Use existing reformat aromatics resources
- Combine with other sources (PyGas)
- Combine Aromizing investment with Gasoline blend objectives

Option 1: Use Reformate C8A

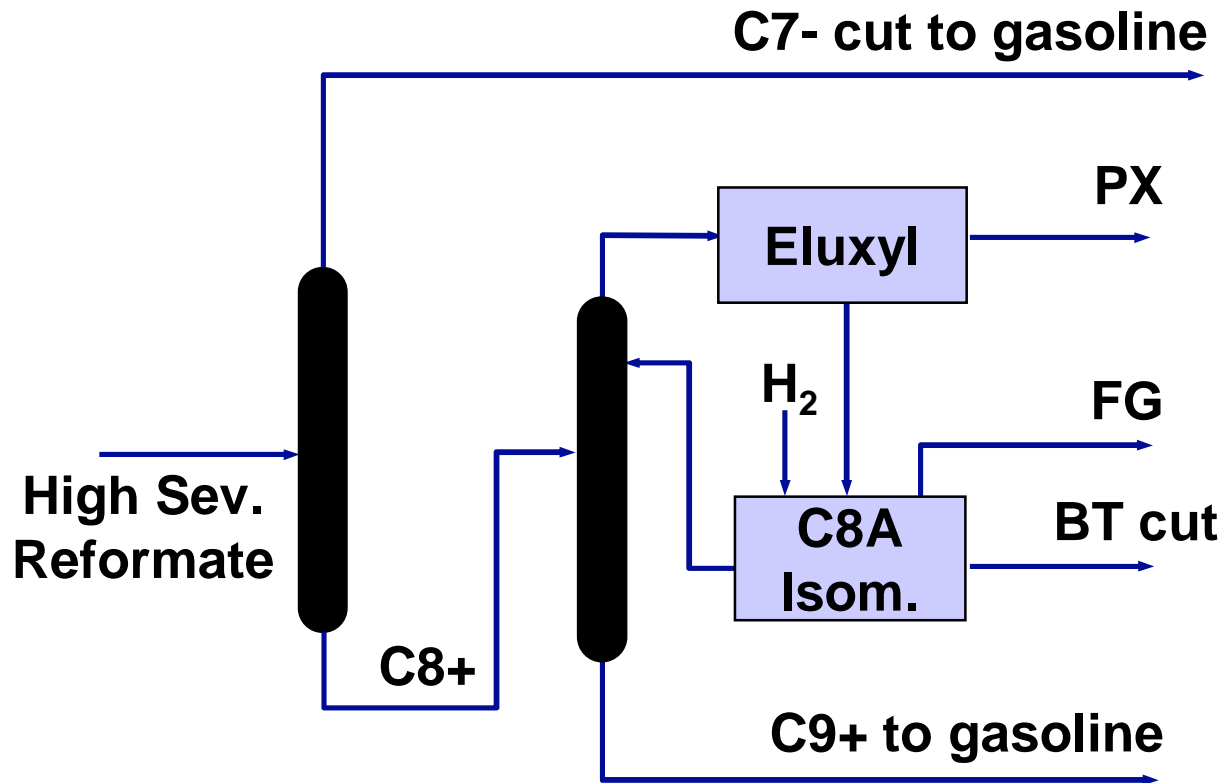

Maximize PX/C8A
Minimize Hydraulics

- ü **Minimize C8A losses**
- ü **Maximize PX/C8A in isom**
 - PX ATE
 - EB conversion / ATE

Xylenes Isomerization, EB dealkylation to benzene

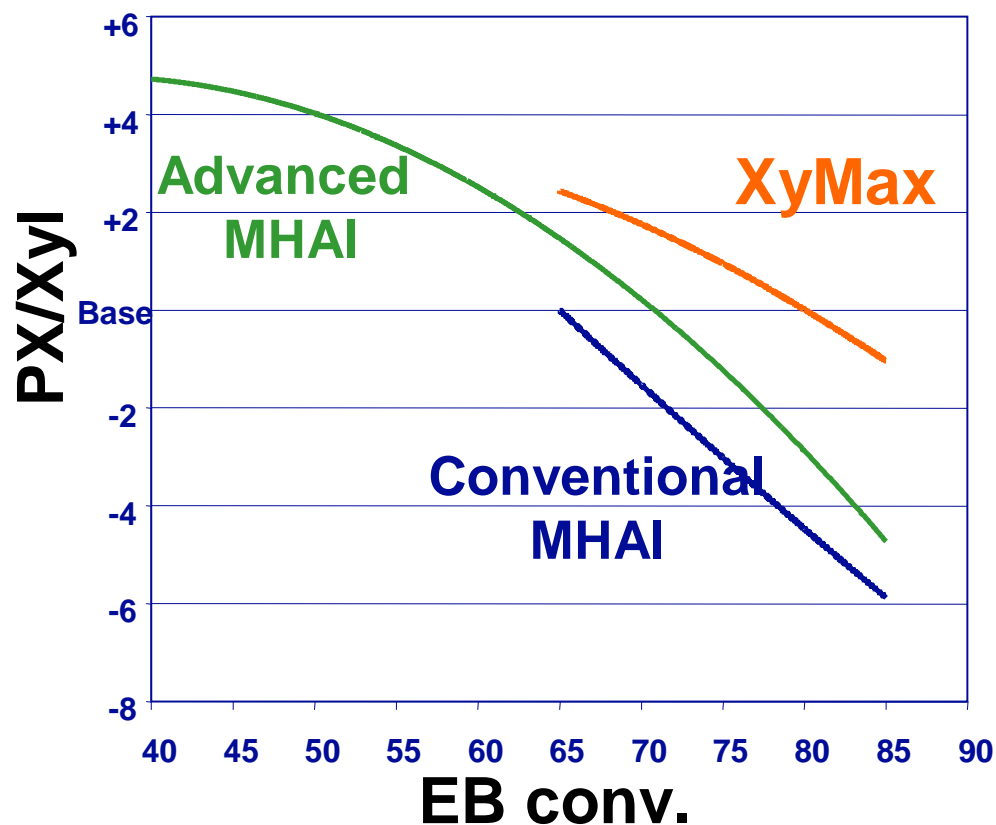

- Four units in operation (17 overall)
- EB conversion from 60% to 85%
- PX / X ~ Thermodynamic equilibrium at reactor outlet
- High selectivity
- High WHSV low H₂/HC

EB and Xylenes Isomerization

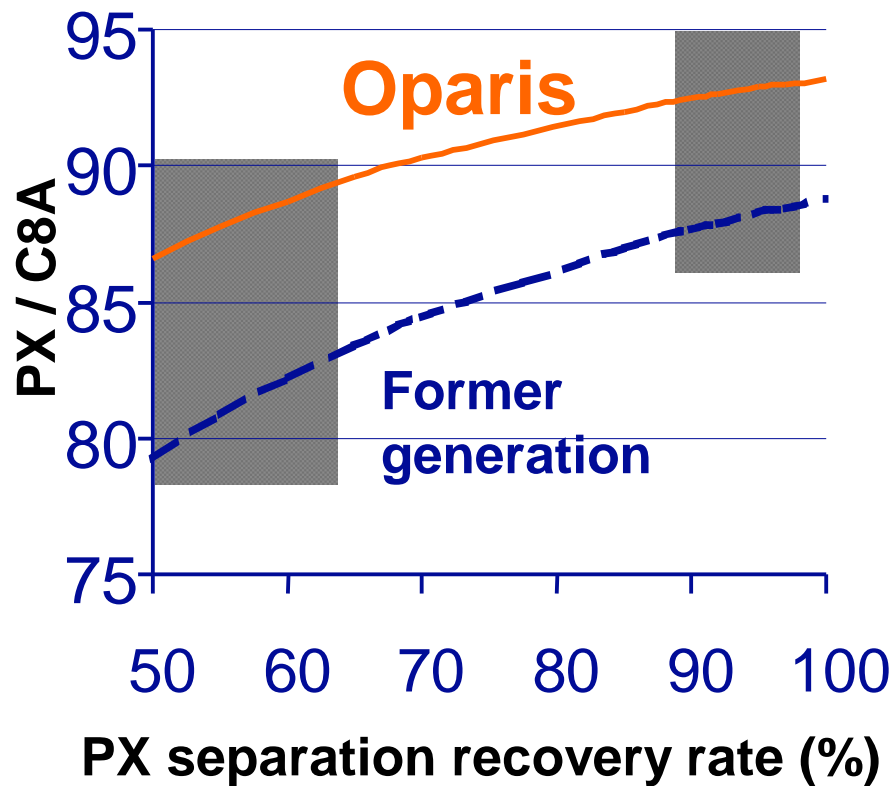

- **Two units in operation**
- **25% more active**
- **PX “ATE” ~ 97%**
- **EB ATE from 40% to 60%**

Option 1 - Yield Summary

	Oparis Option	XyMax Option
Total reformat, kTPA	1400	925
C8A in reformat, kTPA	432	152
Mixed C8A import, kTPA		340
Paraxylene, kTPA	400	400
Crude Benzene, kTPA	-	60
Reformat C8A fraction to PX block, %	~100	~55
RON clear penalty	- 3.8	- 1.8
MON clear penalty	- 2.6	- 1.4

- **Oparis option yields ~92% PX from C8A**
- **XyMax option yields ~97% PX from Xylenes**
- **Octane penalty has a linear pattern**

Option 1 - Capex and Opex Summary

- Ø XyMax option features 15% Capex, 20% Opex advantage**
 - high EB conversion
 - benzene co-product

- Ø Oparis option offers maximum PX / C8A yield**
 - equilibrium limited EB conversion
 - no benzene co-production

Option 2 - Reformate & Pygas

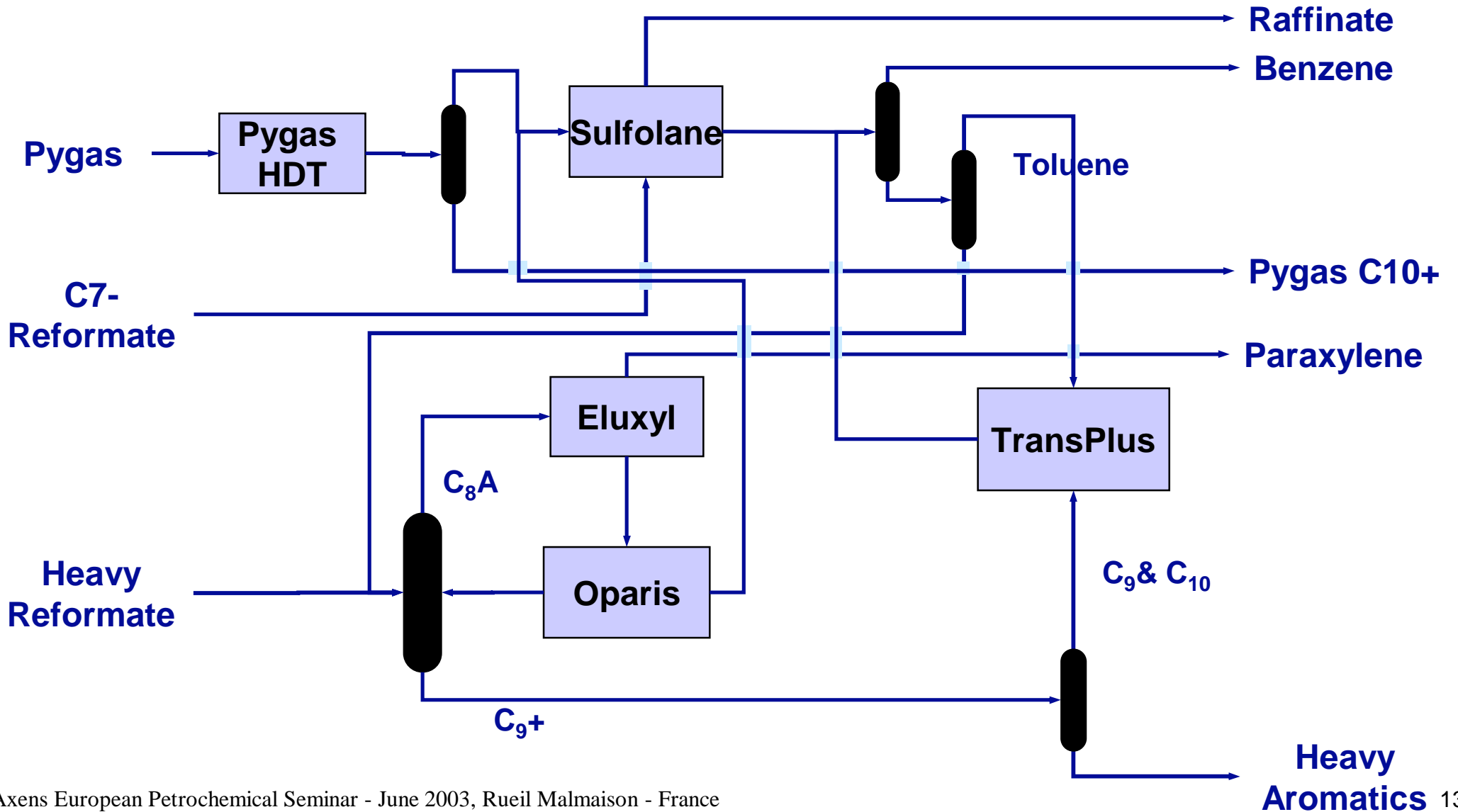

Option 2 - Feedstock Contributions

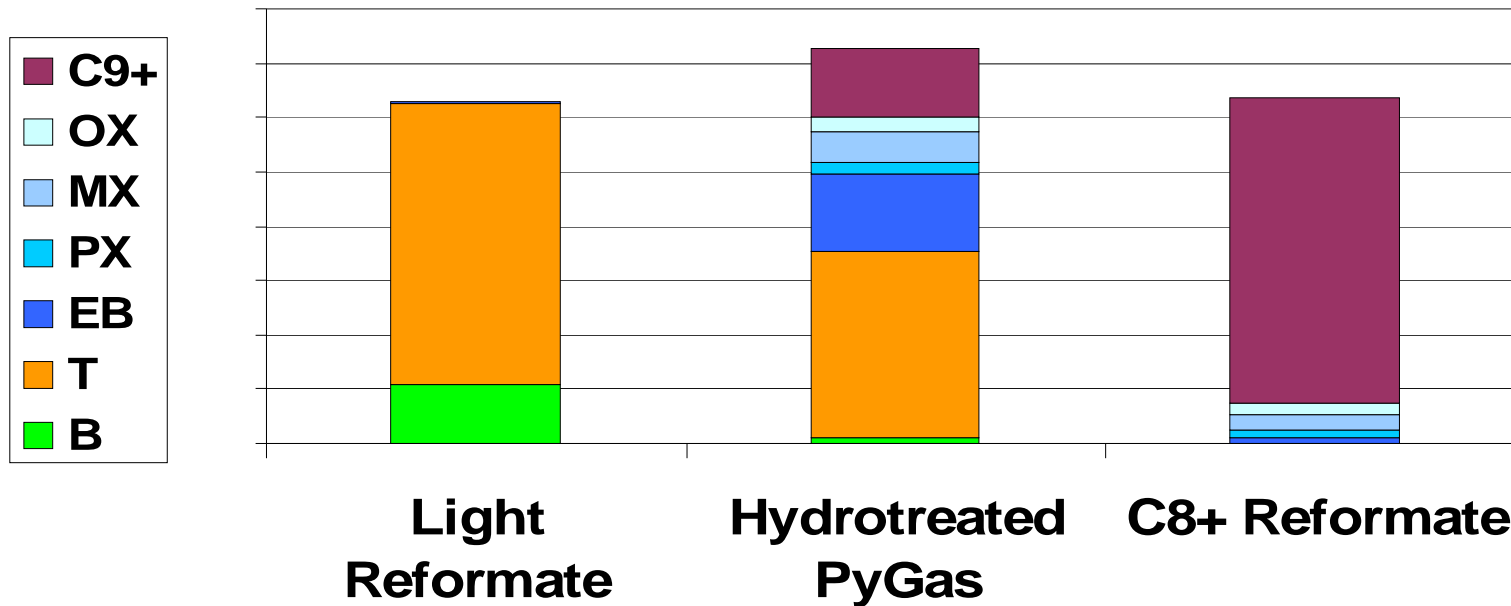

- **Low C8A content in net feeds**
- **High EB content in C8A**

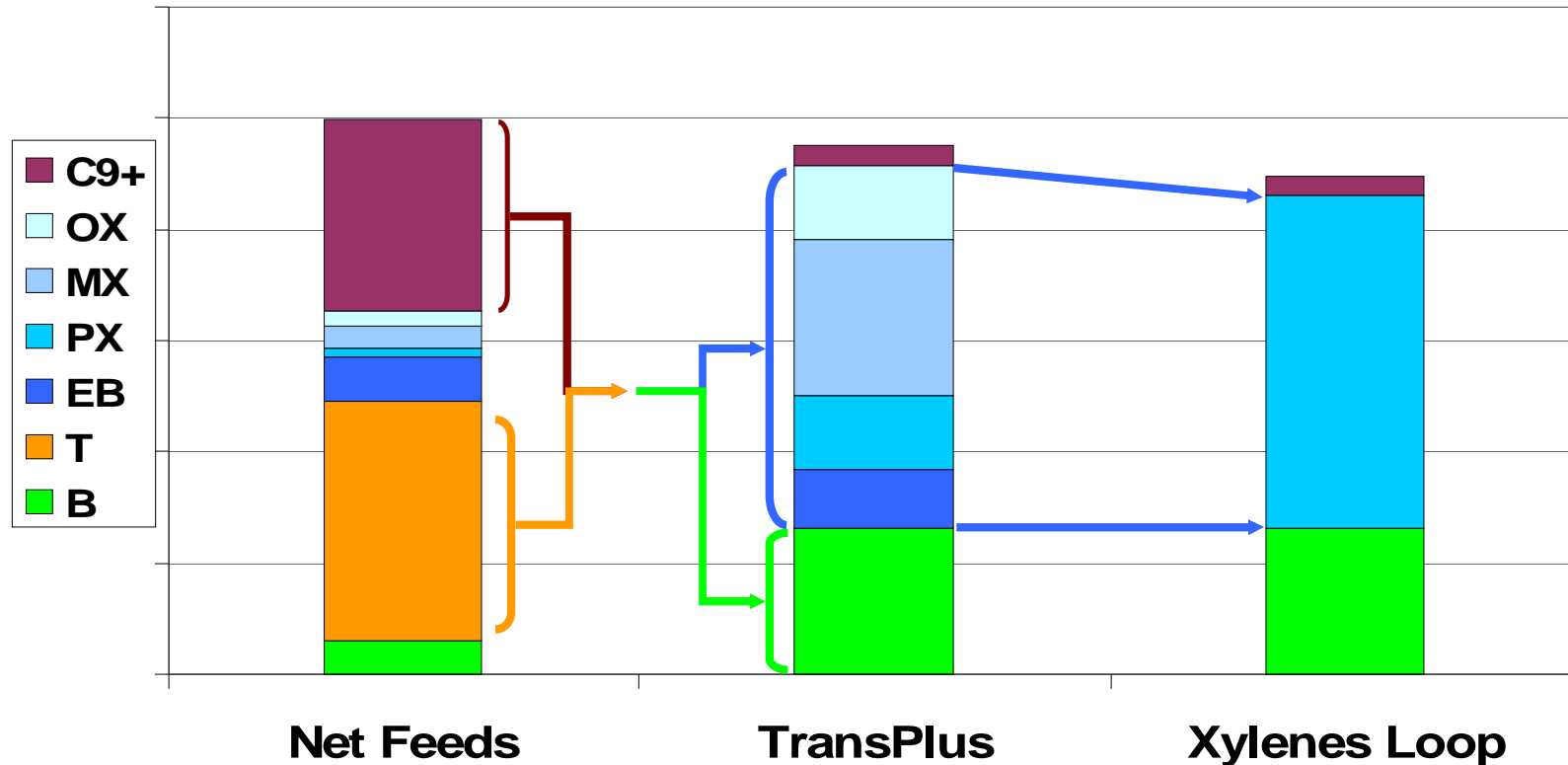

- **TransPlus yields 75% of C8A to the Xylenes Loop**
- **TransPlus and HPG C8A mix into Reformate C8A distribution**

Relative CAPEX Analysis

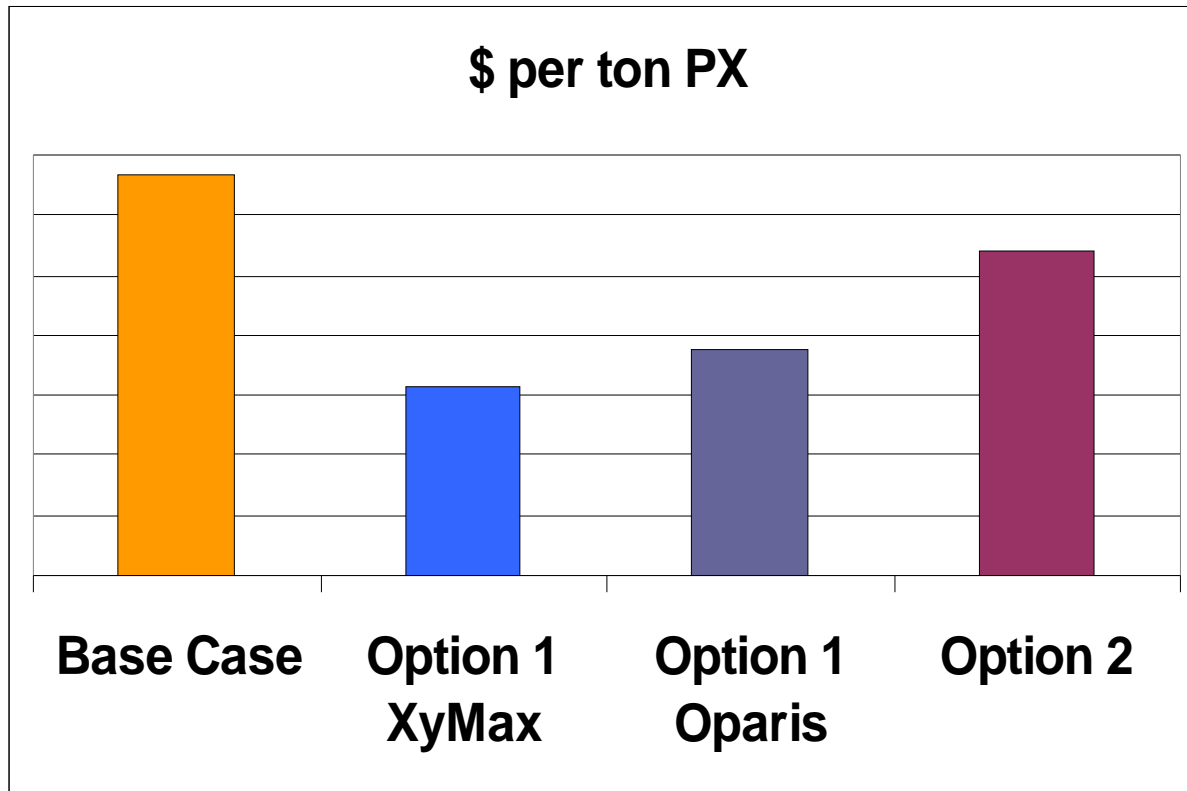

- **Significant advantage for Option 1**
- **Option 2 - favorable shift from Ring generation to aromatics purification**

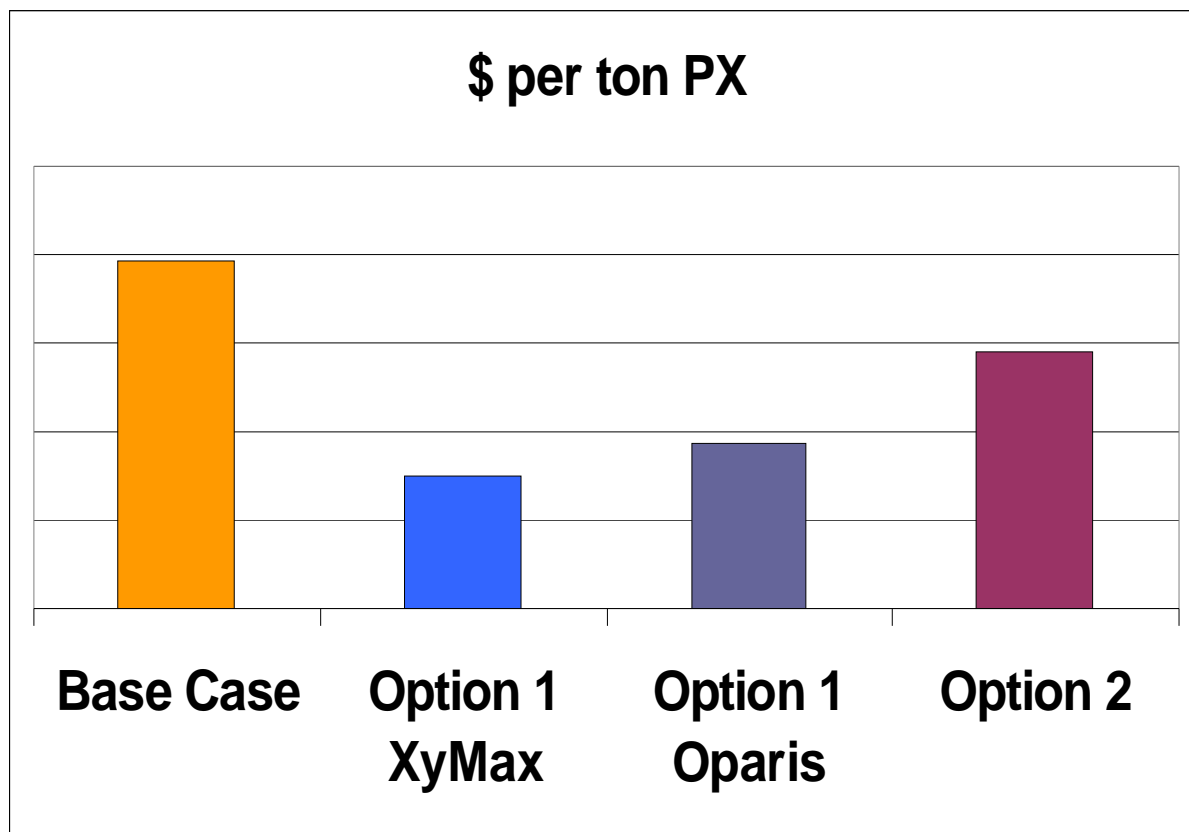

- Opex directionally identical to CAPEX
- Wider gap between Option 1 XyMax vs Oparis
- Option 2: Wider relative gain to Base Case

- Ø Opportunities to produce lower cost PX exist**
- Ø Concerns:**
 - Think large scale: aromatics processing hub**
 - Fair HPG pricing**
- Ø Each case is specific: Axens' ParamaX suite of technologies answers all scenarios with single source solutions**

Refinery Petrochemical Integration Alternate Routes to Produce Paraxylene