

Getting the Maximum out of Selective Hydrogenation Catalysts

Q. Debuisschert

Axens

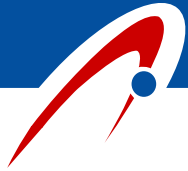

- **Contamination Issues**
- **Case Studies & Solutions**
 - **Pretreatment Solutions**
 - **Catalyst Solutions**
 - **Process Solutions**
- **Commercial Feedback**

Axens Fully Integrated Services

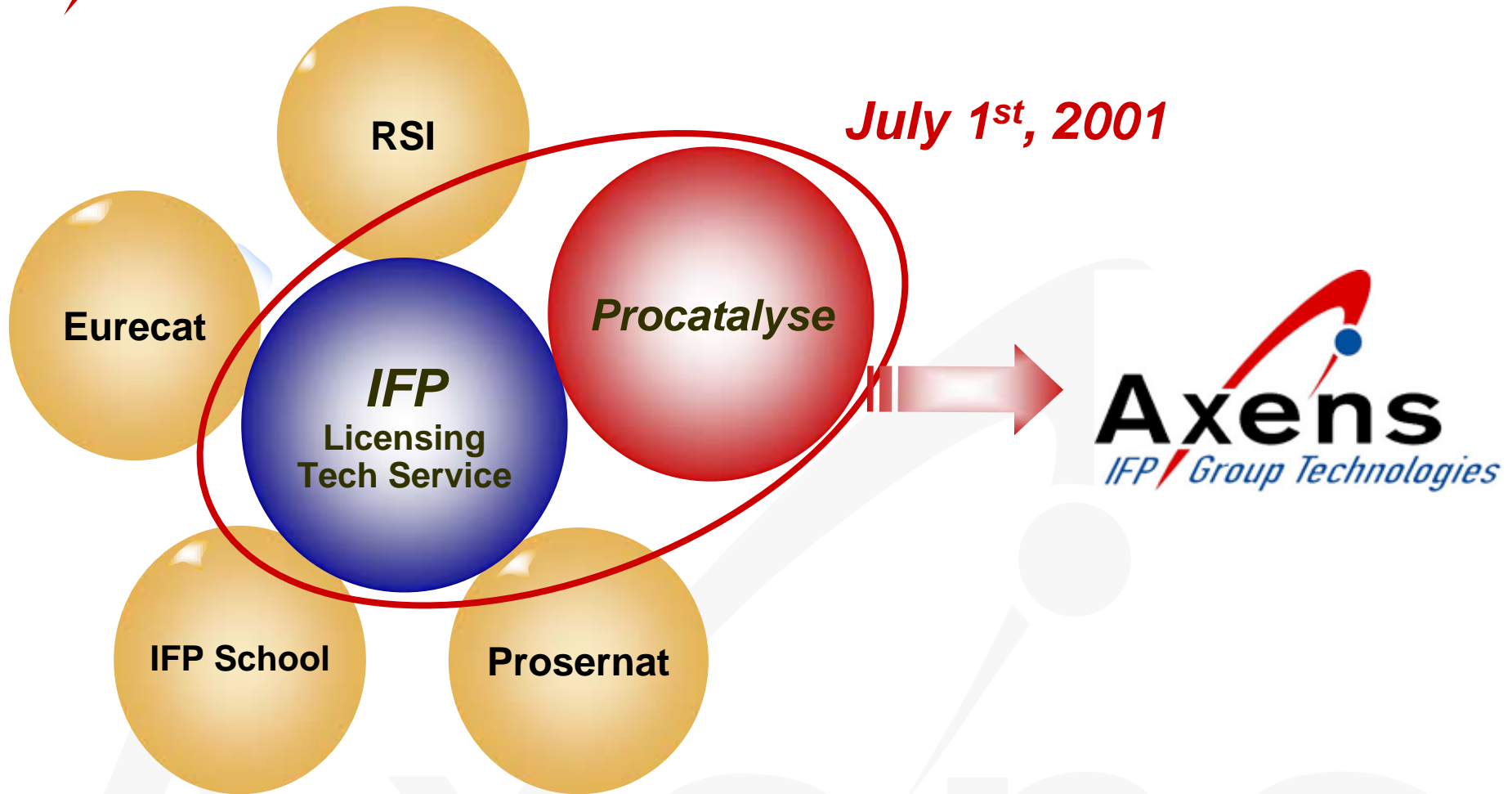
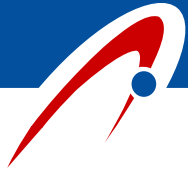

Axens Core Business: Licensing, Catalysts, Services

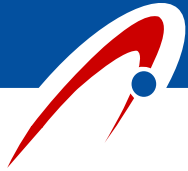

- **Contamination Issues**
- **Case Studies & Solutions**
 - Pretreatment Solutions
 - Catalyst Solutions
 - Process Solutions
- **Commercial Feedback**

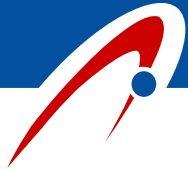

- **Capacity Increase Requirements**
- **Severity Increase Constraints (Pygas)**
- **Enhanced On Stream Factor**
- **Cracker Profits Challenged**
- **Processing of Opportunity Feedstocks**
 - **Imported Feedstock to Hydrogenations**
 - **Lower Value Feedstock to Crackers (Condensates, Gasoils, ...)**
 - **Potential Contamination**

Deactivation Principles

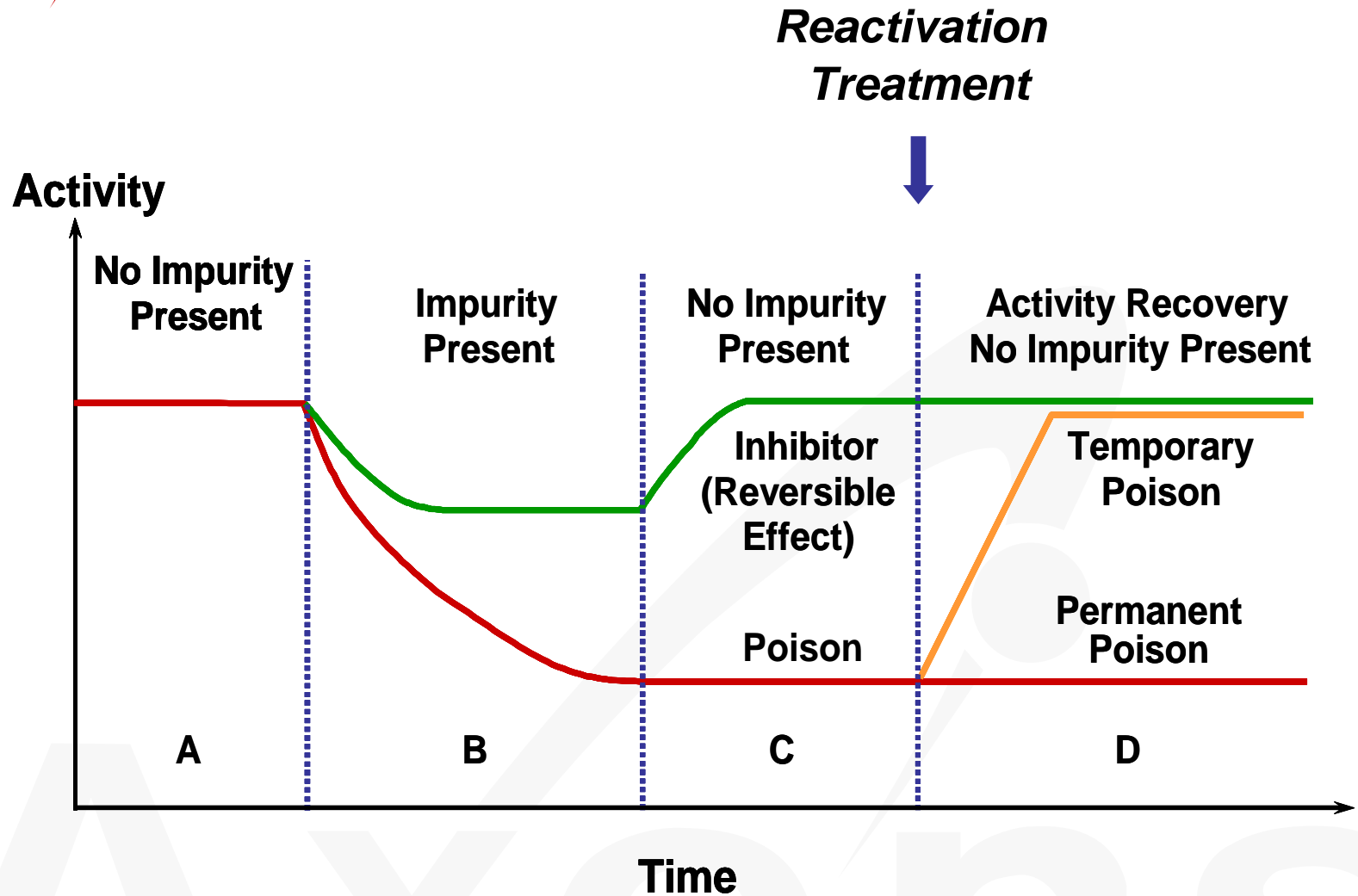
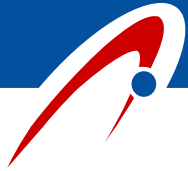



Contaminant Quantification

- Analysis in Hydrocarbons
- Development of Refined Methods at ppb Level



Evaluation of Contaminants Effects

- IFP R&D Facilities
- Poisoning Effect Evaluation
- Mitigation Solutions



Industrial Experience

- Variety of Case Studies
- 4000 Spent Catalysts Analyses

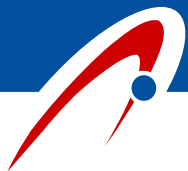

Axens/IFP Contamination Experience

Frequency of Appearance, %

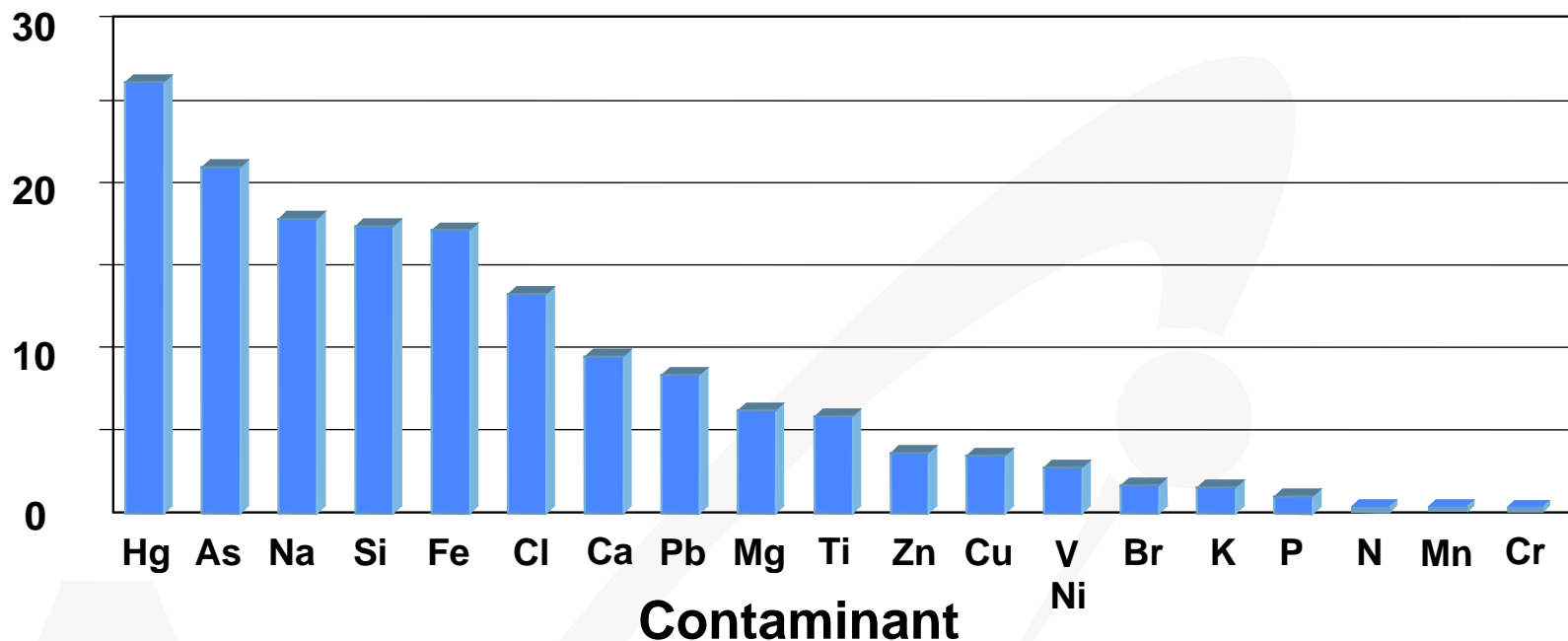

4000 Catalyst Analyses

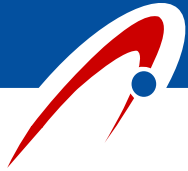

- **Contamination Issues**
- **Case Studies & Solutions**
 - **Pretreatment Solutions**
 - **Catalyst Solutions**
 - **Process Solutions**
- **Commercial Feedback**



- **Heavy Feedstocks to Crackers**
- **Presence of COS in C₃ Cuts**
- **Decomposition into H₂S onto Pd**
- **H₂S Catalyst Poison**

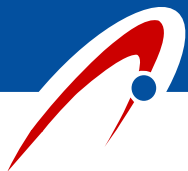

C₃ SHU Catalyst Deactivation with COS

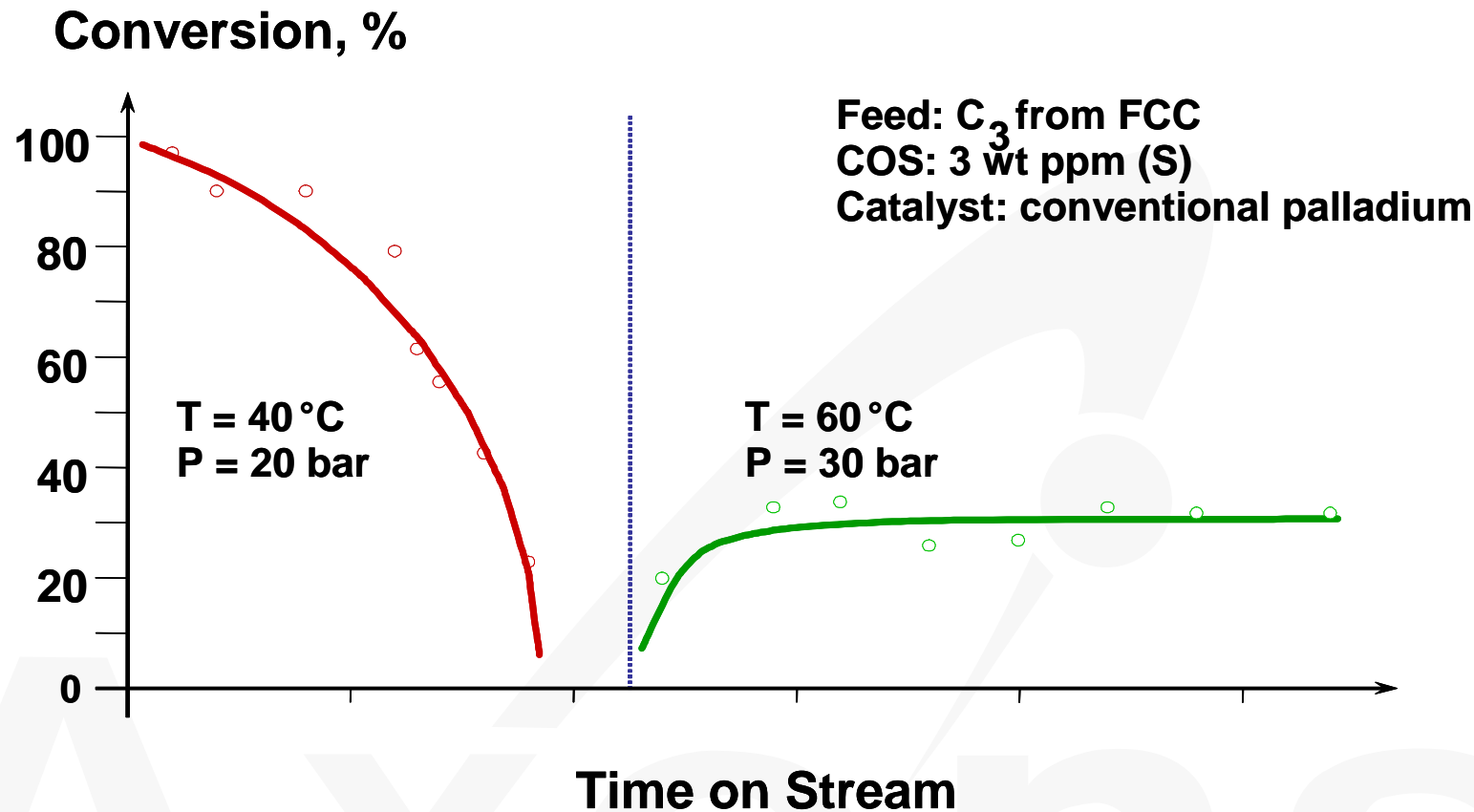

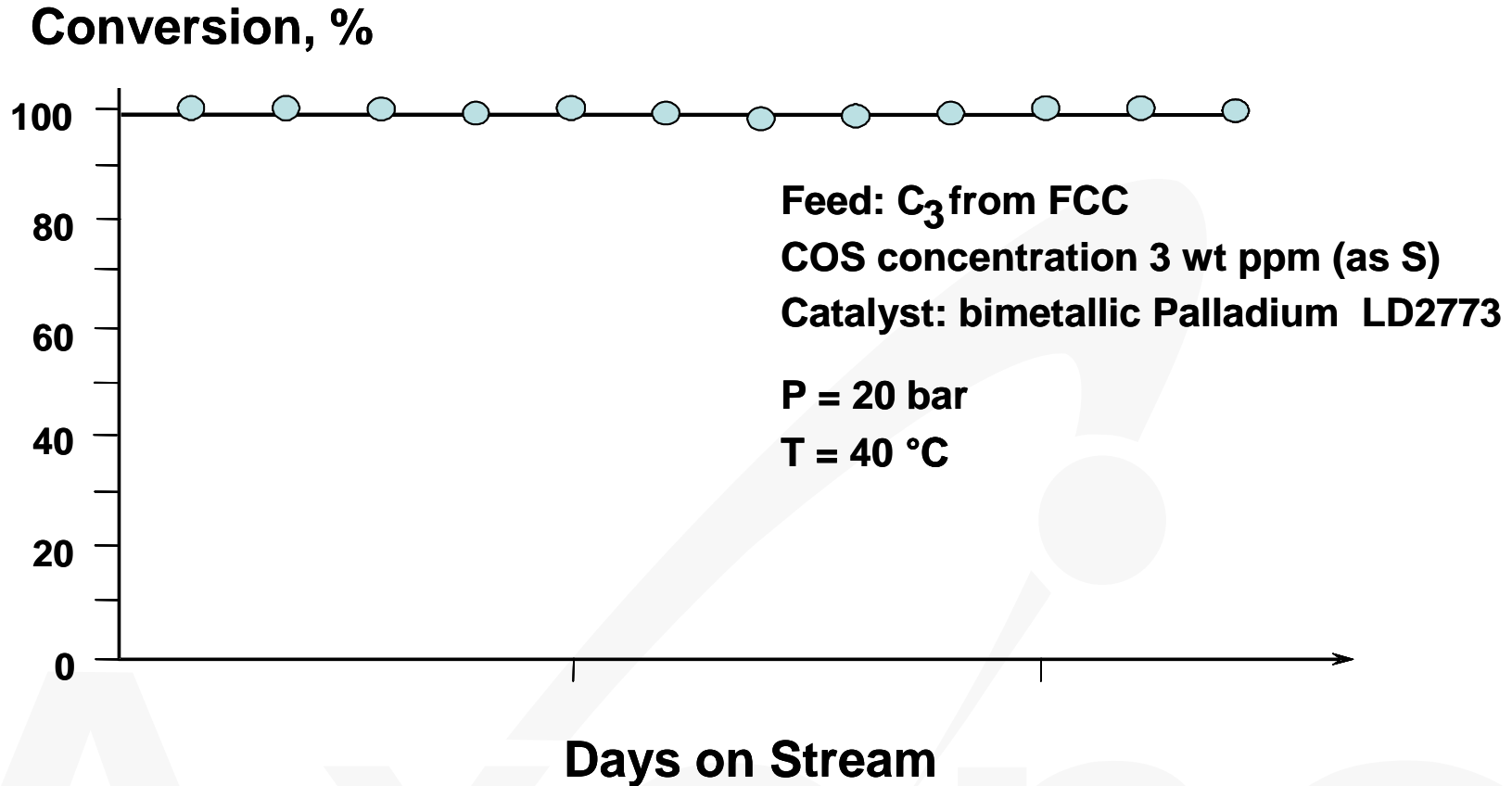
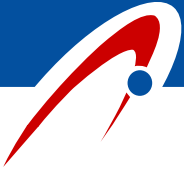

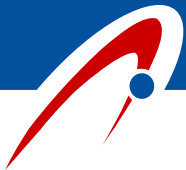

Pretreatment Solution - Multibed™

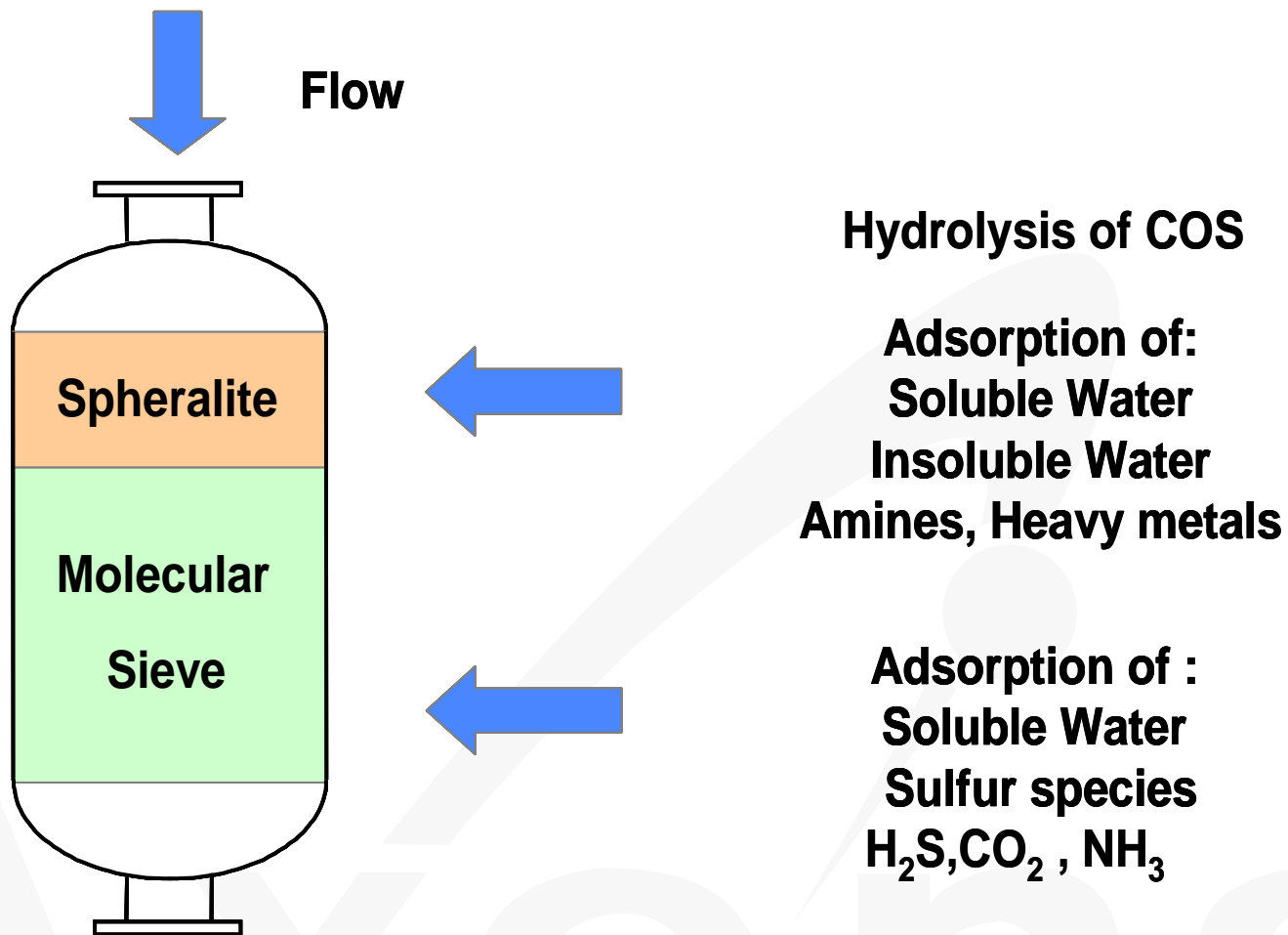

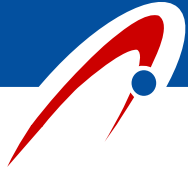

Conversion, %

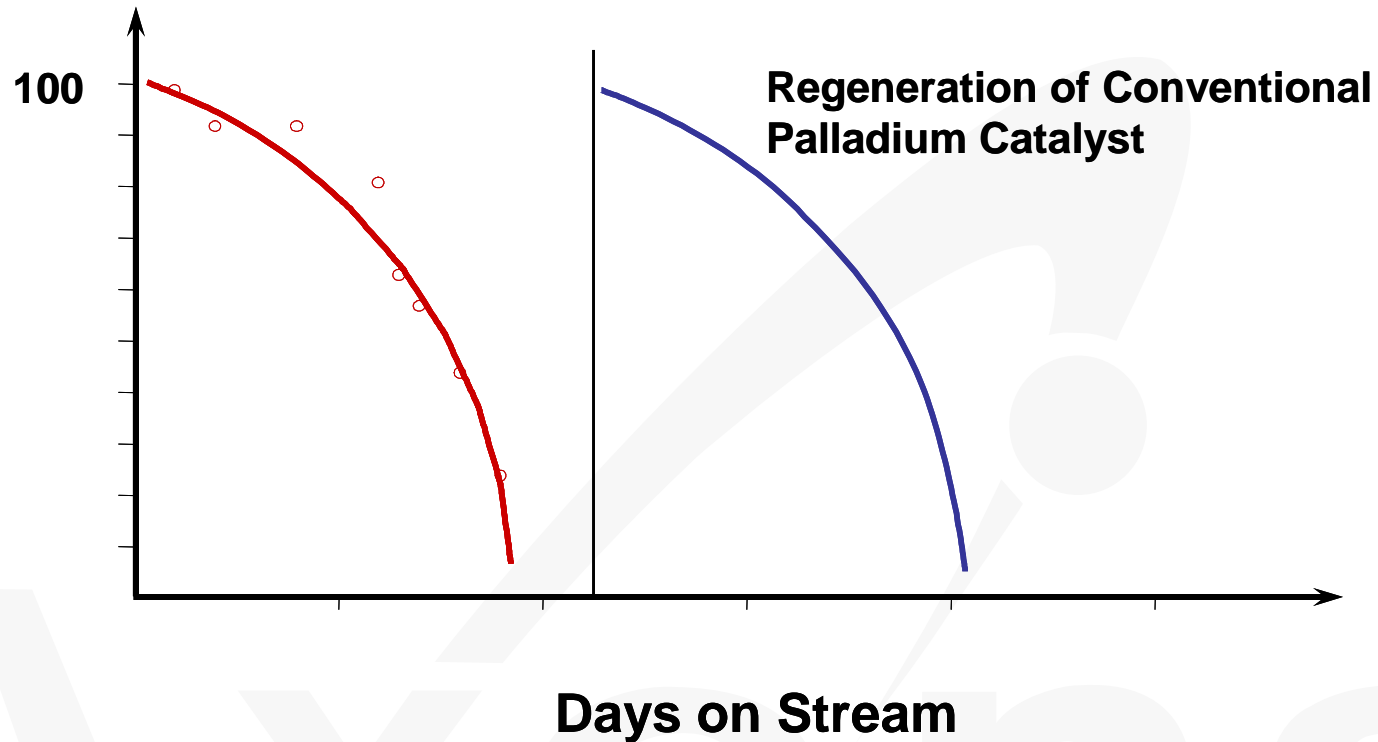

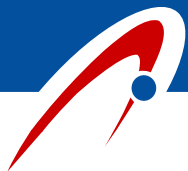

Catalytic Solution for As in C₃/C₄ Cuts

- **As from Heavy Feedstocks to FCC**
- **C₃/C₄ Cuts Contaminated with AsH₃**
- **As Temporary Poison**
- **Activity Recovered by Regeneration**
- **Requirement for Highly Stable Catalysts**
- **LD 265 - up to 50 Regenerations**

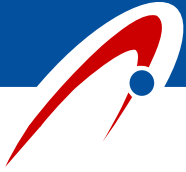

MultiBed™ Performance for As/Hg

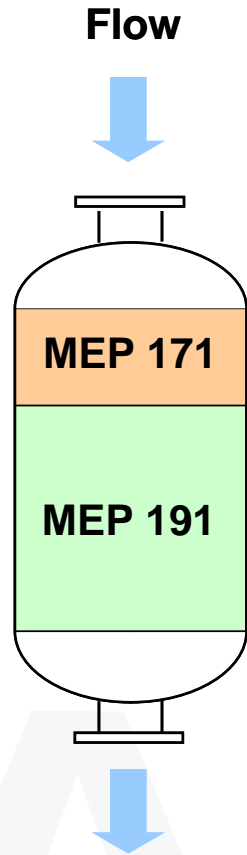

- ✓ ***Lead Oxide Trapping System***
- ✓ ***Effective in Presence of RSH***
- ✓ ***As, Hg and COS Removal***
- ✓ ***As in Feed: 100-1000 wppb***
- ✓ ***As in Product < 0.5 wppb***
- ✓ ***Hg in Product < 1.0 wppb***
- ✓ ***Safe Operation***

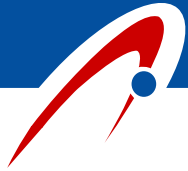

- **Profits on Cracker Challenged**
- **Tendency for Opportunity Feedstocks**
- **Increasing Trend towards Contaminants**
- **Main Contaminants: Si, As, Hg**

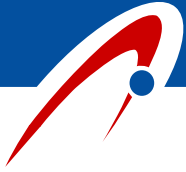

Pretreatment Solution: RAM II

**Organometallic
Hydrogenolysis and
Arsenic Adsorption**

**Mercury
Adsorption**

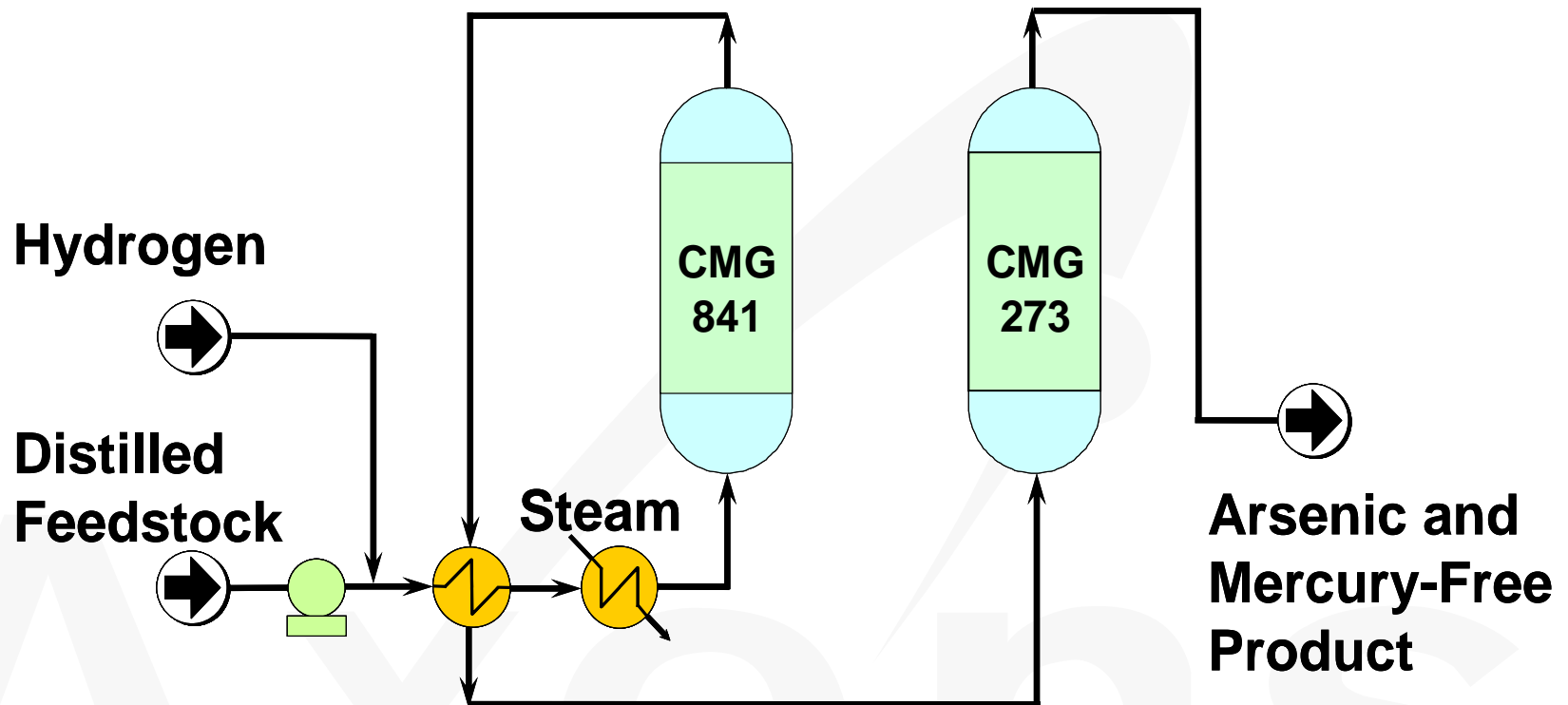

RAM II Process Industrial Experience

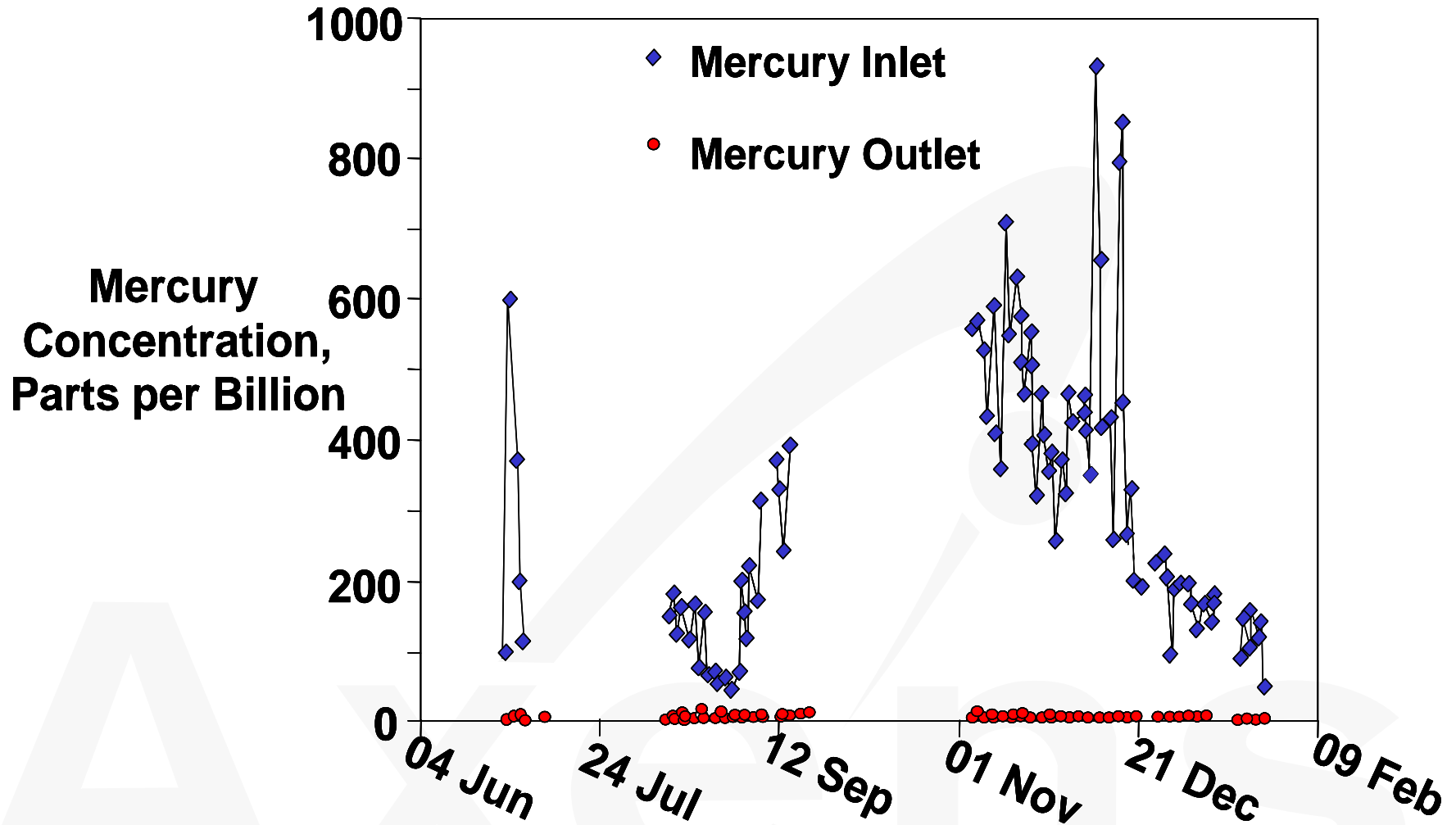
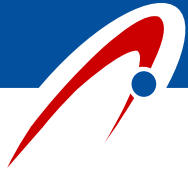

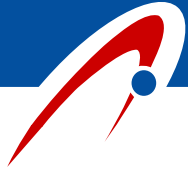

- **Switch from Pd to Non Noble Metal (Ni)**
 - **Much Higher Metal Loading**
 - **Higher Tolerance to Impurities (LD341)**
- **Low Cost Pd Catalysts**
 - **Lower Replacement Cost**
 - **Preservation of Tolerance to Impurities**

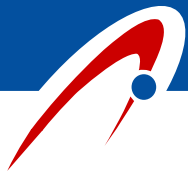

Contaminated Feedstock Replacement of Pd Cat. by LD341

Contaminated Feedstock: As (50-300 ppb), Si, Hg

	Palladium Catalyst	Axens Nickel LD 341
Styrene in Product, wt%	< 0.3	< 0.3
Cycle Length	Base	Base * 5

***Industrial Experience in Asia
Effectiveness of Cat. Replacement by LD 341
Significantly Improved Unit Reliability and
Added Economic Value***



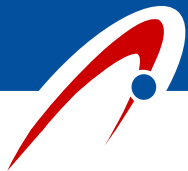

Pd Catalyst Solutions – New Formula

New Formula Compared to Existing *Operating Conditions, Feedstock Type Reactivation, Contaminants Spiking*

Conversion

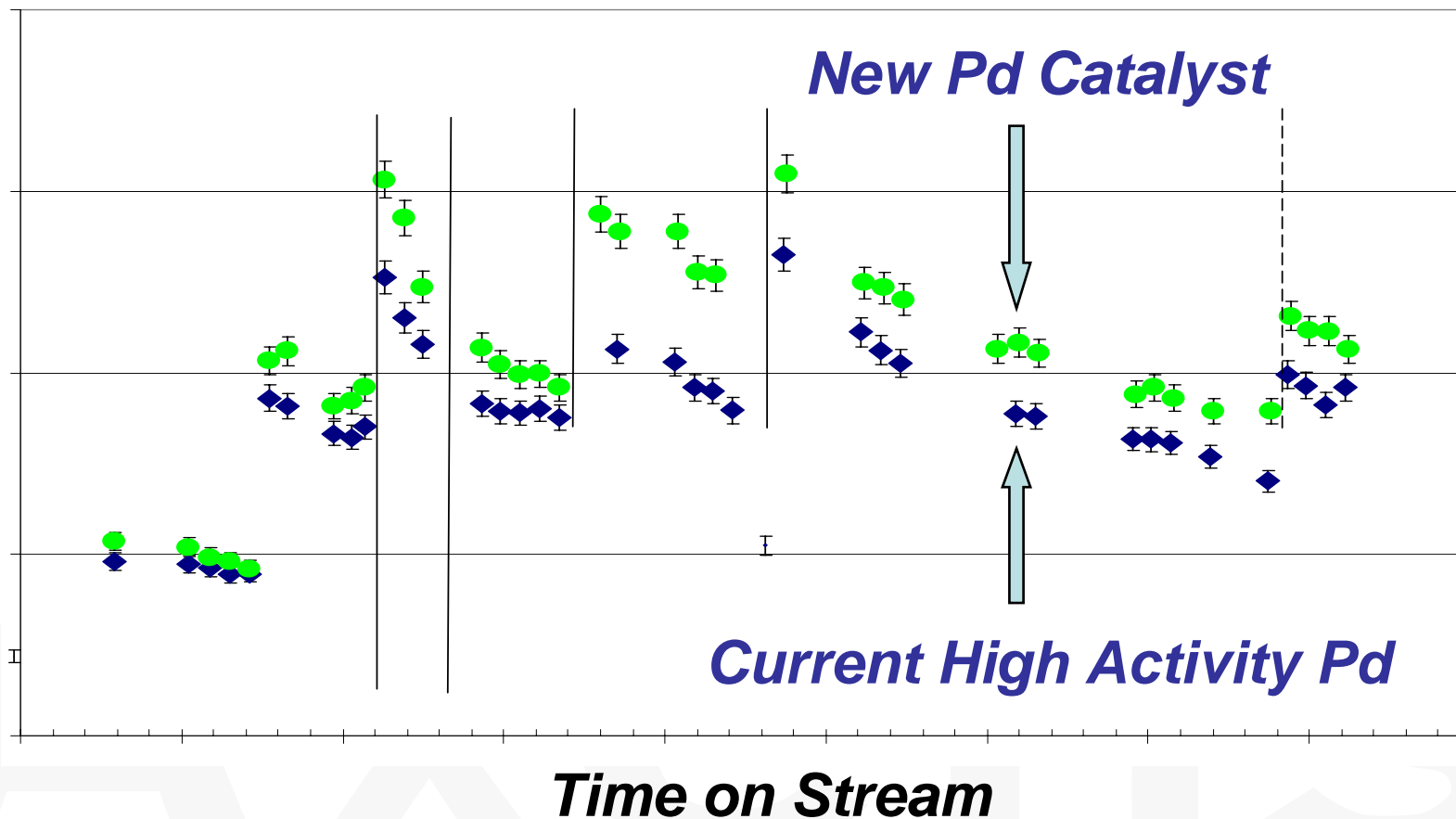

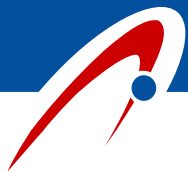

As Compared to Existing Highest Activity Pd Catalysts

- **Higher Activity**
- **Equivalent Tolerance to Impurities**
- **Lower Inventory Cost**
- **Lower Pd Loading (30% to 50 % Less)**

Potential Breakthrough Product

LD465



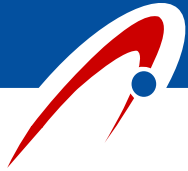

- **Contamination Issues**
- **Case Studies & Solutions**
 - Pretreatment Solutions
 - Catalyst Solutions
 - **Process Solutions**
- **Commercial Feedback**



- **Optimize Distribution**
 - **Minimize Deactivation by Gums**
 - **Maximize Use of All Catalyst Inventory**

- **Mitigate Pressure Drop Issues**
 - **Maximize Cycle**
 - **Prevent Channelling**

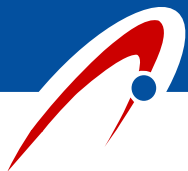

Equiflow™ Applied to Hydrogenations

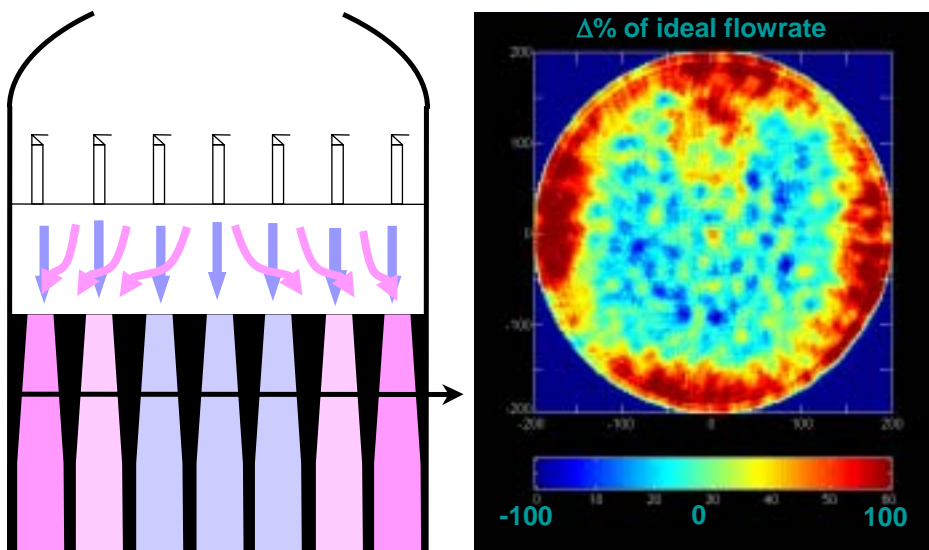

Conventional Chimney Tray

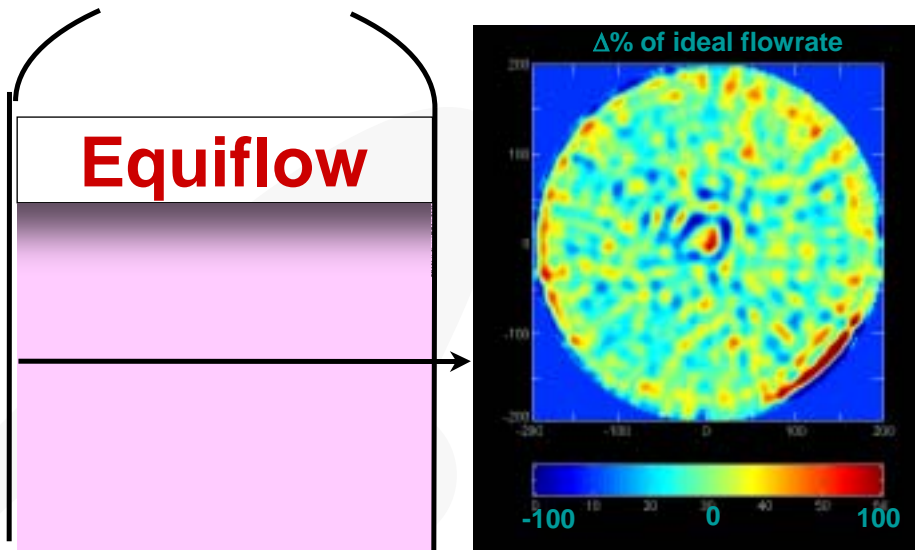

**EquiFlow™
Latest Generation
of Commercial Distributors**

ACT Series Grading Material Commercial Results

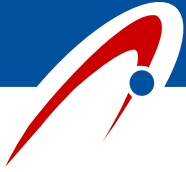

**Reactor Pressure
Drop
No ACT**

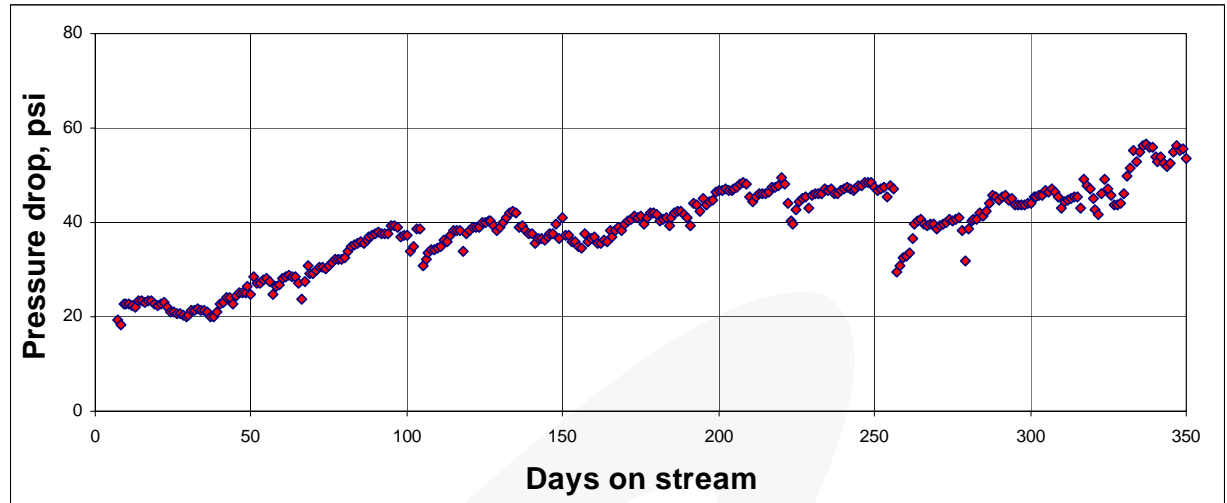

**Reactor Pressure
Drop
With ACT**

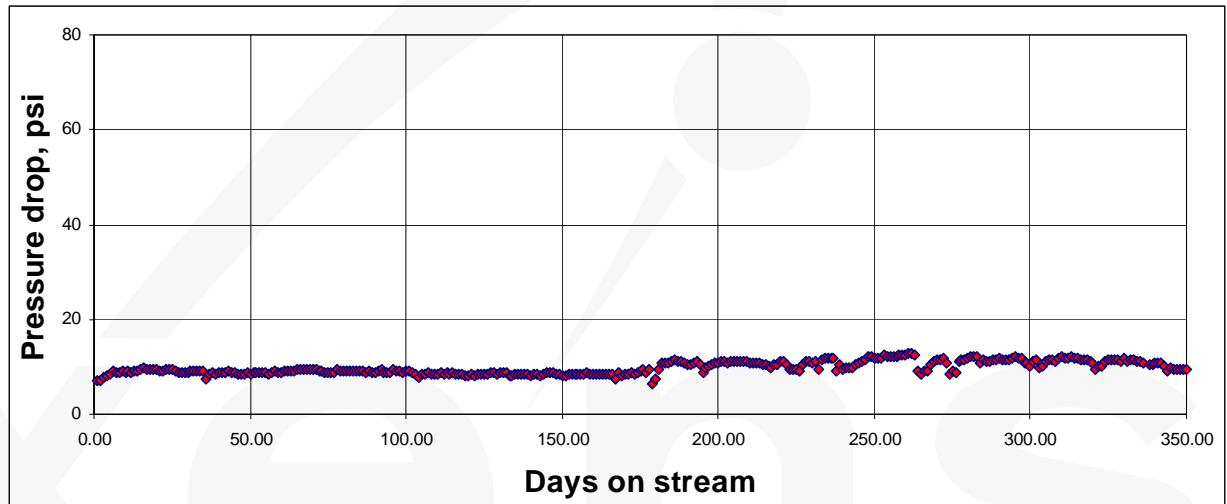



- **Opportunity Feedstocks**
- **Tendency Towards Frequent Contamination**
- **Axens' Expertise in Contamination Issues**
- **Axens' Leading Position in Hydrogenations
(C3, C4, Pygas)**
- **Unrivaled Industrial Experience (500 References)**

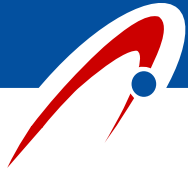

➤ ***Pretreatment Solutions***

- **Multibed™ Systems on Light Cuts**
- **Ram II Process on SC Feed**

➤ ***Catalyst Solutions***

- **Bi-metallic Pd Catalysts (C3/C4/C5)**
- **Non Noble Metal Catalysts (Pygas)**
- **Low Cost Pd Catalysts (Pygas)**

➤ ***Process Solutions***

- **High Efficiency Internals**
- **Pressure Drop Issues Mitigation**

Getting the Maximum out of Selective Hydrogenation Catalysts

Axens